

AIRNET



Installation and Assembly Guide

www.airnet-system.com

fast ***easy*** ***reliable***

TABLE OF CONTENTS

Need to Know.....	3
Pre-Installation.....	4-7
Installation.....	8-10
Assembly	11-17
• Diameters 20 - 80mm / 3/4" - 3".....	11 - 13
• Diameter 100mm / 4"	14 - 16
• Quick Drop Assembly (Diameters 20 - 80mm / 3/4" - 3")	17
Safety and Security.....	18-19

NEED TO KNOW

THE AIRNET SYSTEM

- brings the required pressure to the exact point of use with a minimal pressure drop.
- transports the air to the exact point of use to increase the efficiency of the manufacturing process.
- makes sure the air quality remains the same at the quality air equipment outlet as at the various points of use over time.
- performs the installation with minimum downtime. The system can be pressurized immediately after assembly.
- anticipates future requirements, and provide the necessary flexibility for future evolution.
- reduces downtime, the selected installation material enables an extension or maintenance of the network in minimum time.

What is the furthest point pressure drop?

The furthest point **pressure drop** is the difference in pressure between the point of generation and the furthest point in your installation.

A high **pressure drop** means the regulating pressure on the compressor needs to be set higher to compensate for the **pressure drop**.

As a 1 bar (15 psi) additional operating pressure results in about 7% higher energy consumption, **pressure drops** drastically increase the electrical bill.

The **pressure drop** is influenced by various factors which we can classify from highest to lowest impact:

The pipes' inner diameter

Increasing the pipes' inner diameter reduces the **pressure drop** but increases the investment.

Free air delivery

The air demand of all downstream equipment connected to the portion of network.

The friction factor

Related to the pipe's material. Aluminium has a very low friction factor as opposed to galvanized pipes.

The length of the network

The longer the network, the higher the **pressure drop**.

The structure

It is recommended to build a ring in order to reduce your **pressure drop**.

Working pressure

When the working pressure is lower, the **pressure drop** increases.

To evaluate the pressure drop in a typical installation

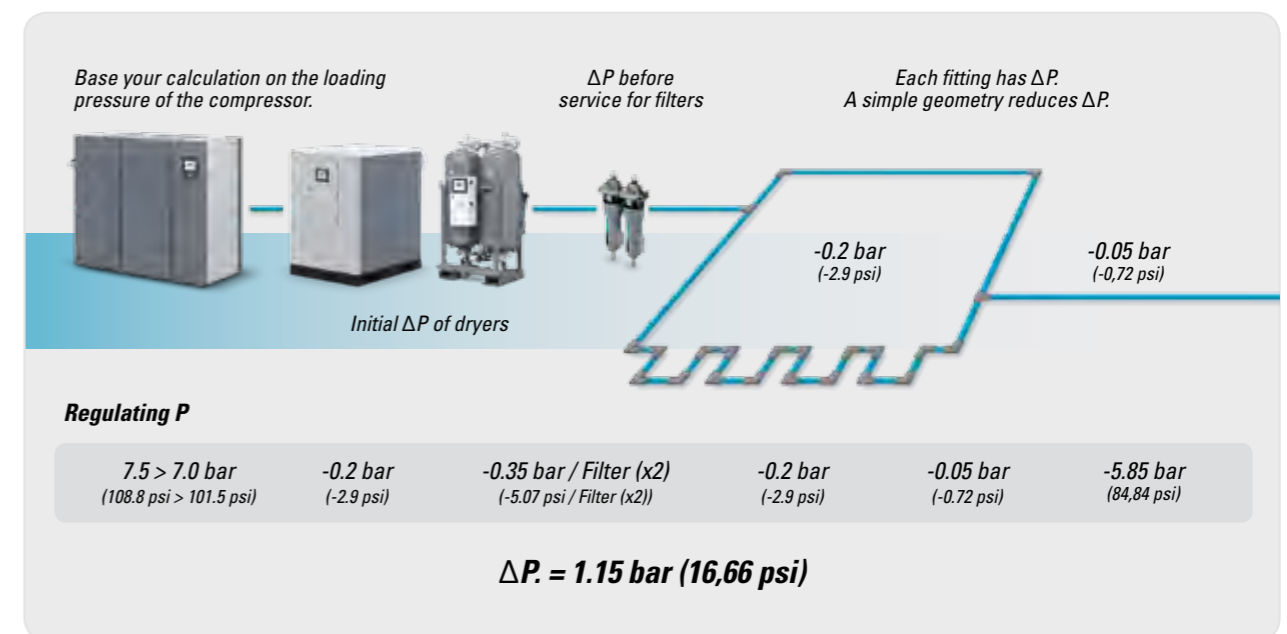

Always design your network so that the loading pressure at the compressor (7.0 bar) is minimized in order to reduce energy consumption.

Always anticipate some pressure flexibility, e.g. if the furthest point pressure requirement is 5.9 bar (85.57 psi), the network specification of the above example would have to be reviewed.

!
These data are only valid when the network consists solely of AIRnet equipment designed to guarantee a low pressure drop.

BEFORE INSTALLATION

Evaluate special network configurations



- Bypassing major obstacles may require hoses in order to limit the pressure drop in a complex AIRnet geometry.
- Can the quick drops' length and design be standardized or should they be customized to each point of use?
- Valves can be used to isolate network sections.
- Long straight lines may require expansion loops in order to absorb the dilatation.

Long straight pipes can expand or contract due to temperature variations. To compensate for this effect, expansion loops are required. The number of expansion loops depends on the total length of the straight line and the maximum temperature variation.

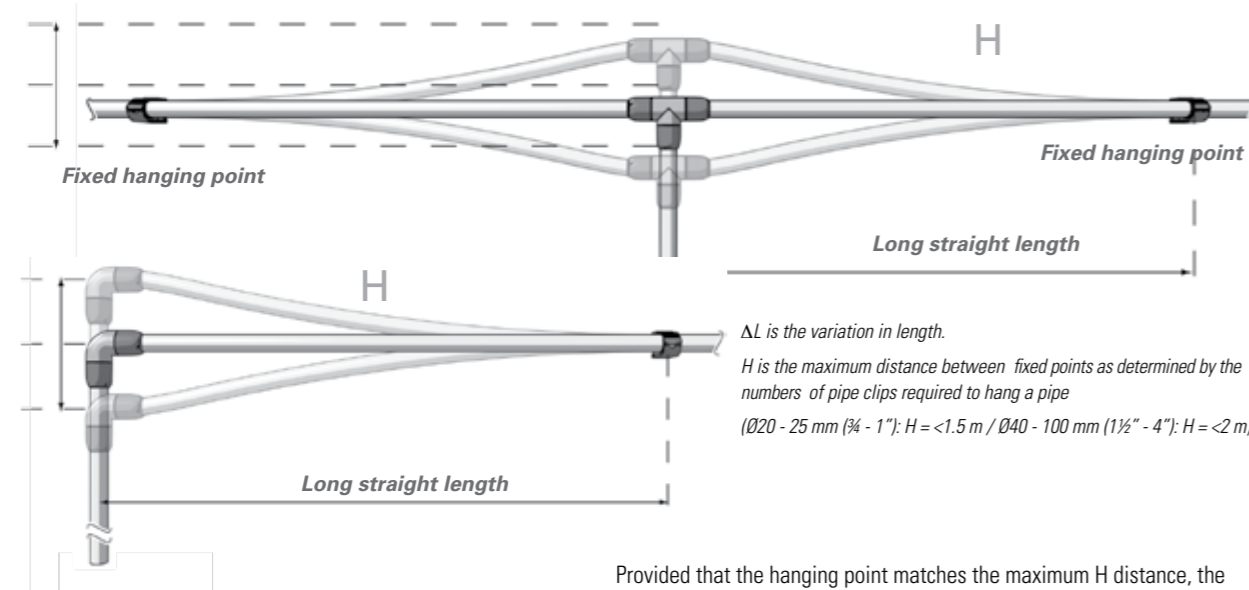

Provided that the hanging point matches the maximum H distance, the below table clarifies the maximum possible straight distance vs. the temperature variation. When the length of the straight line exceeds the maximum, expansion loops are required to compensate for the variation in length.

DT	Ø20 mm / 3/4"	Ø25 mm / 1"	Ø40 mm / 1 1/2"	Ø50 mm / 2"	Ø63 mm / 2 1/2"	Ø80 mm / 3"	Ø100 mm / 4"
5°C / 41°F	211 m / 692 ft	168 m / 551 ft	187 m / 614 ft	150 m / 492 ft	119 m / 390 ft	94 m / 308 ft	75 m / 247 ft
10°C / 50°F	159 m / 522 ft	127 m / 417 ft	141 m / 463 ft	113 m / 371 ft	90 m / 295 ft	71 m / 233 ft	57 m / 186 ft
20°C / 68°F	107 m / 351 ft	85 m / 279 ft	95 m / 312 ft	76 m / 249 ft	60 m / 197 ft	47 m / 154 ft	38 m / 123 ft
30°C / 86°F	80 m / 262 ft	64 m / 210 ft	71 m / 233 ft	57 m / 187 ft	45 m / 148 ft	36 m / 118 ft	29 m / 94 ft
40°C / 104°F	64 m / 210 ft	52 m / 171 ft	57 m / 187 ft	45 m / 148 ft	36 m / 118 ft	29 m / 95 ft	23 m / 76 ft

BEFORE INSTALLATION

Plan your Airnet

Since most customers like to visualize their future installation, and because we want to offer them the flexibility to adjust, modify and validate their future installation, we have developed a unique 3D software to quote installation jobs.

More than just a presentation tool for our end-users, the AIRnet Planner provides a detailed network structure and calculates the pressure drop in the system.

Starting from the 3D design, the AIRnet Planner creates the bill of material, specifies the exact number of pipes needed, lists all required AIRnet fittings and calculates the assembly time.

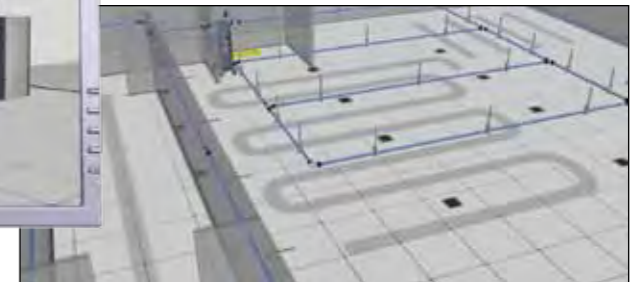

BEFORE INSTALLATION

INSTALLATION GUIDE

NEED TO KNOW

PRE-INSTALLATION

INSTALLATION

ASSEMBLY

SAFETY & SECURITY

NEED TO KNOW

PRE-INSTALLATION

INSTALLATION

ASSEMBLY

SAFETY & SECURITY

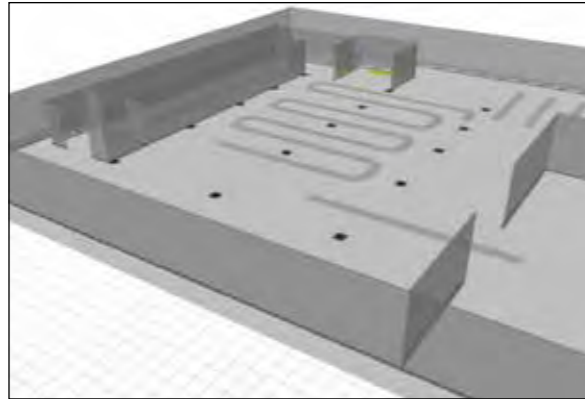

Get your plant dimension drawing

Create a network skeleton

- Main Ring
- Distribution Line
- Cross Ring Lines
- Drop Legs

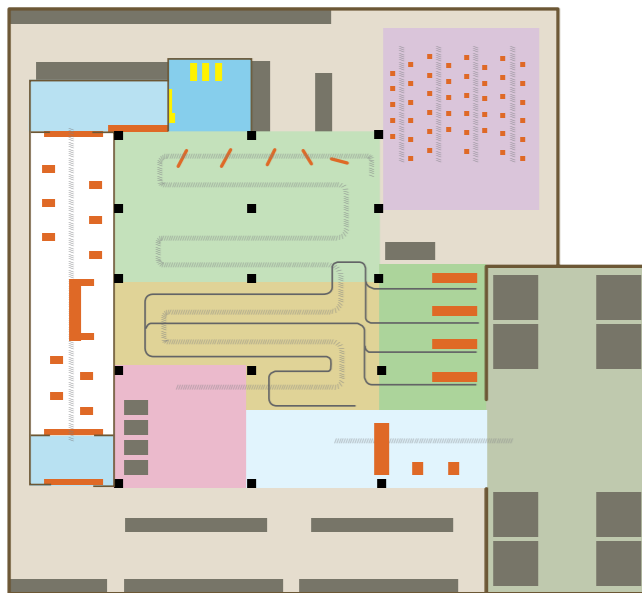
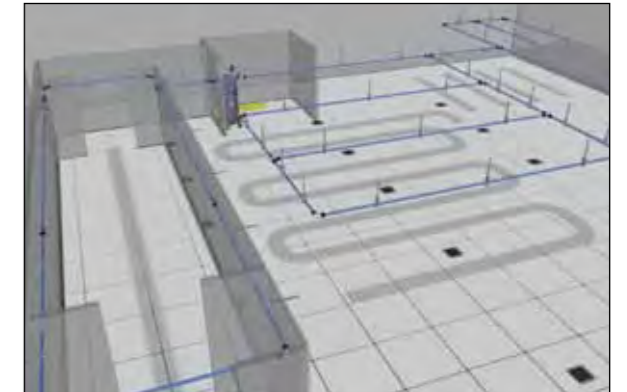

- Parts Storage
- LCD Panel Manufacturing
- Compressor Room
- Clean Room Air Lock
- Frame Assembly
- Quality Control Area
- Final Assembly
- Plastic Injection Moulding
- Shipping
- Packaging
- Clean Room
- Machinery
- Compressed Air equipment
- Storage Bay

Identify the major air demand locations, including the location of the compressor. Evaluate the consumption level of these locations to make a distinction between high volume consumers (requiring a distribution line) and low volume, point of use consumers (requiring a quick drop).

Validate the hanging solution for your network layout

Make sure that the construction of your plant allows you to install the network layout you create. Keep in mind that the selected hanging solution should be safe, and should require the least possible installation time. We offer multiple hanging systems to fit any plant construction.

Connection manufacturing processes

Inventory the numbers of thread inlets and outlets in your compressor room to define the nipple sockets' requirements.

What type of connection will you use to connect your system to the various points of use? Can these be standardized to wall mounted connections?



INSTALLATION GUIDE

Finalize the bill of material

Tick off the below checklist to make sure nothing is forgotten:

Do you have all necessary equipment for a smooth and successful installation?

- AIRnet pipes
- AIRnet fittings
- Pipe clips
- S-bend to reduce the distance between the pipe and the wall
- Special equipment, like hoses and valves
- Nipple sockets to connect from and to the manufacturing process
- Bushing or reducing equipment
- Hanging brackets
- Assembly tools
- Lifting equipment
- Additional quick drops for possible future extensions

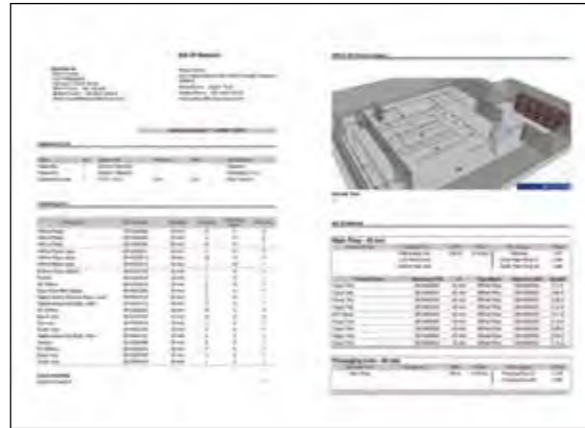

The standard length of an AIRnet pipe is 6 m or 20 ft. As some pipes need to be cut, the required number of pipes does not equal the total length of the network divided by 6 (when calculated in meters) or 20 (when calculated in feet).

Have you calculated the required assembly and hanging time?

ASSEMBLY GUIDE

Diameters 20-80mm / 3/4" - 3"

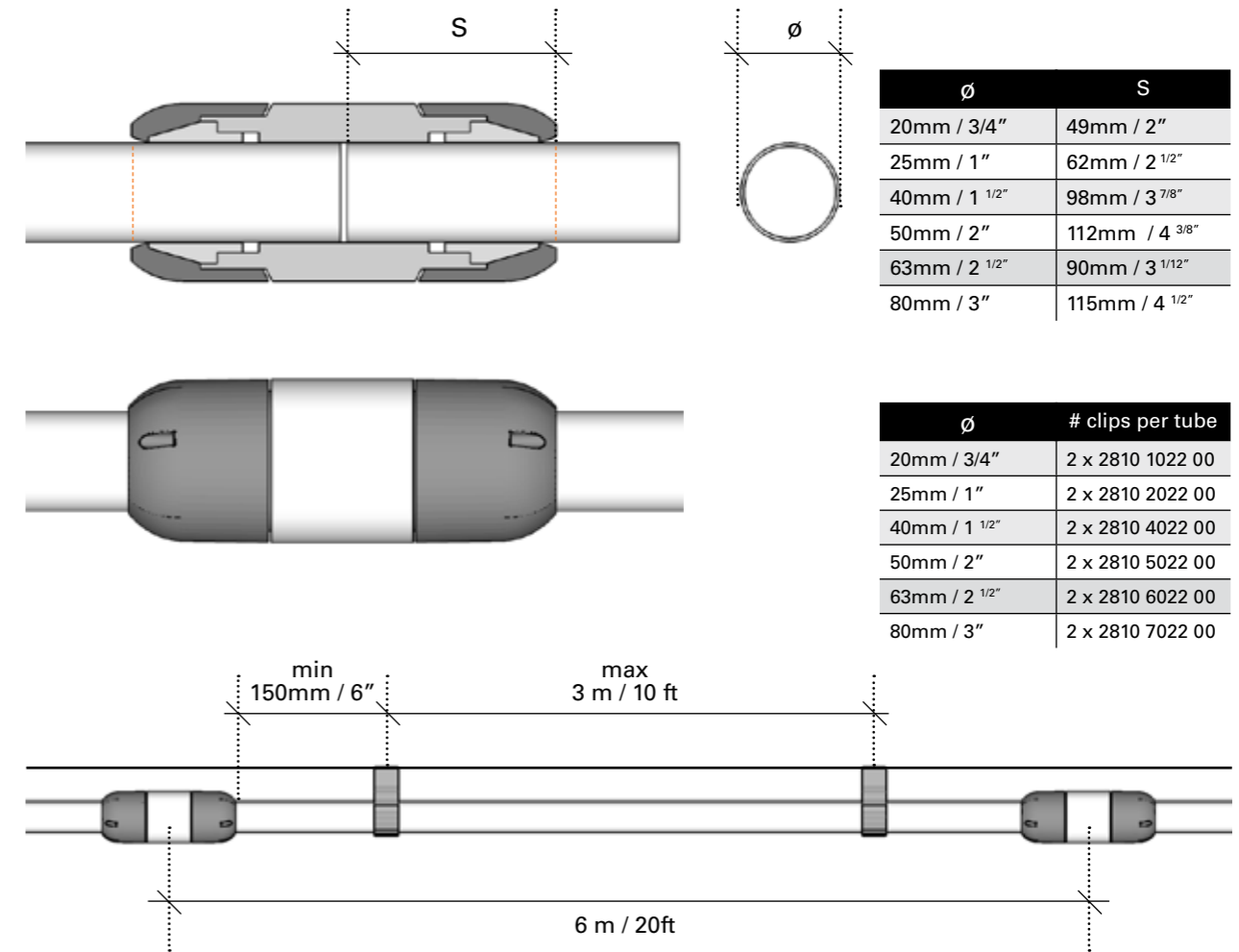

ASSEMBLY GUIDE

Diameters 20-80mm / 3/4" - 3"

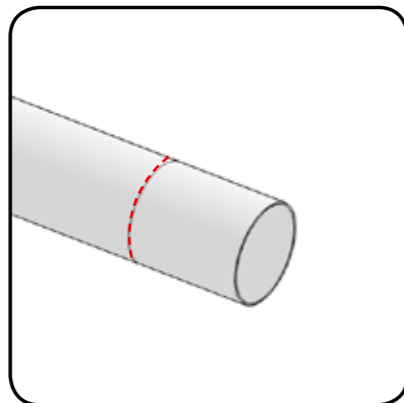
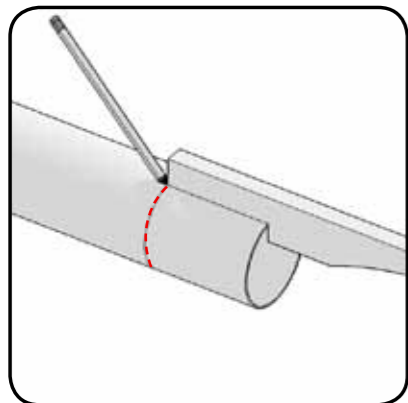
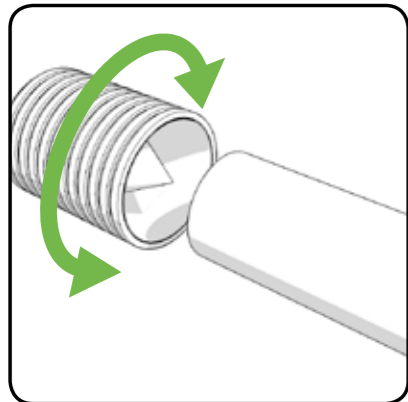
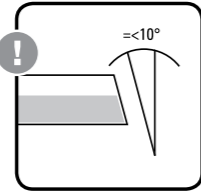
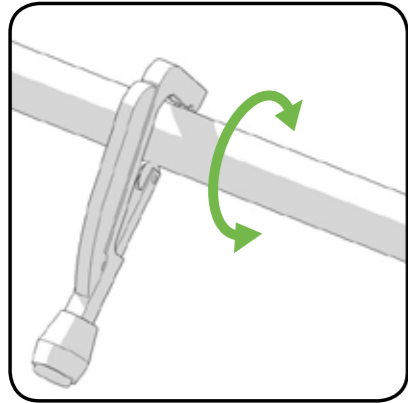

- Ø 20-50 mm 2810 0141 00
- Ø 63 mm 2810 0241 00
- Ø 80 mm 2810 0341 00

ASSEMBLY GUIDE

Diameters 20-80mm / 3/4" - 3"

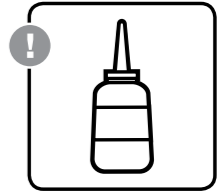
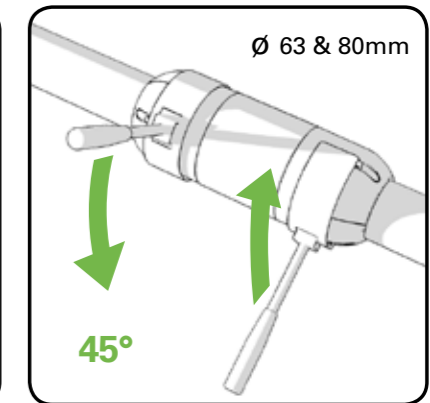
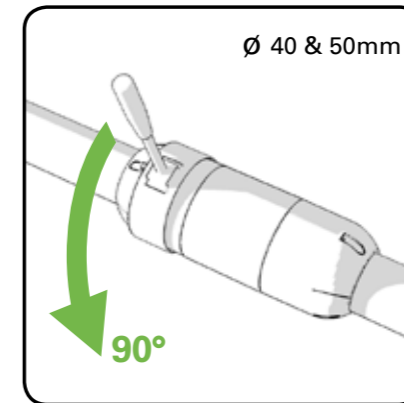
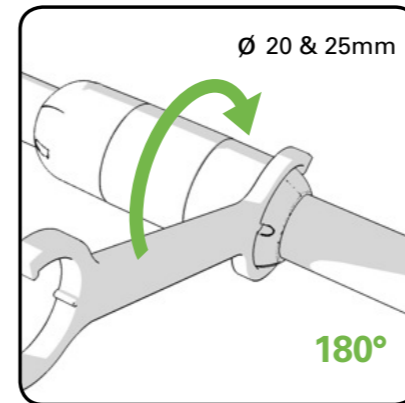
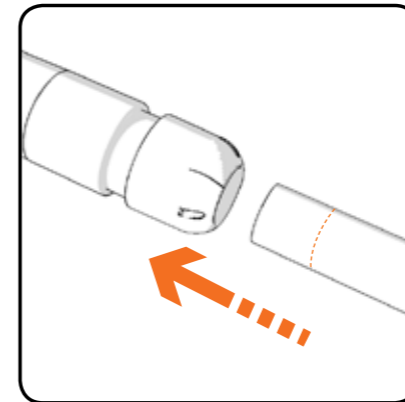
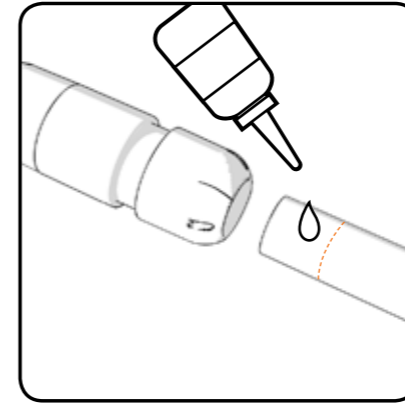

2810 0148 00

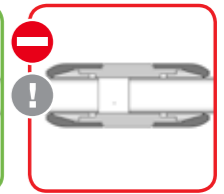
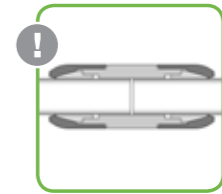

ASSEMBLY GUIDE

Diameter 100mm / 4"

Ø	100mm	4"
L	208mm	8 3/16"
S	6mm	1/4"
T	158mm	6 1/4"

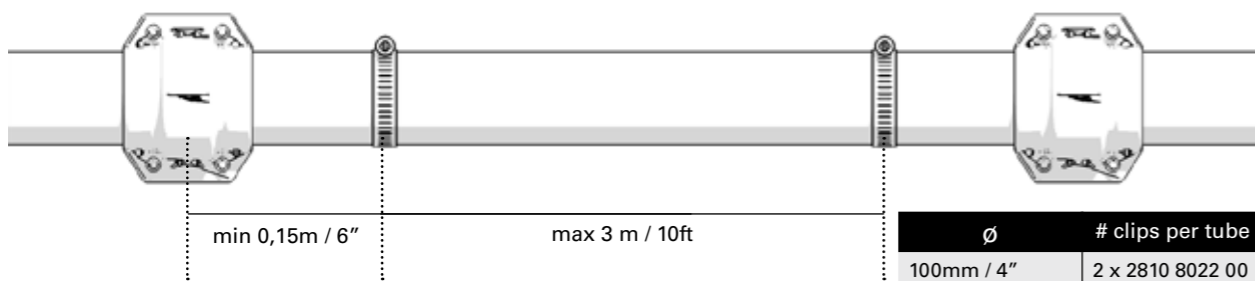
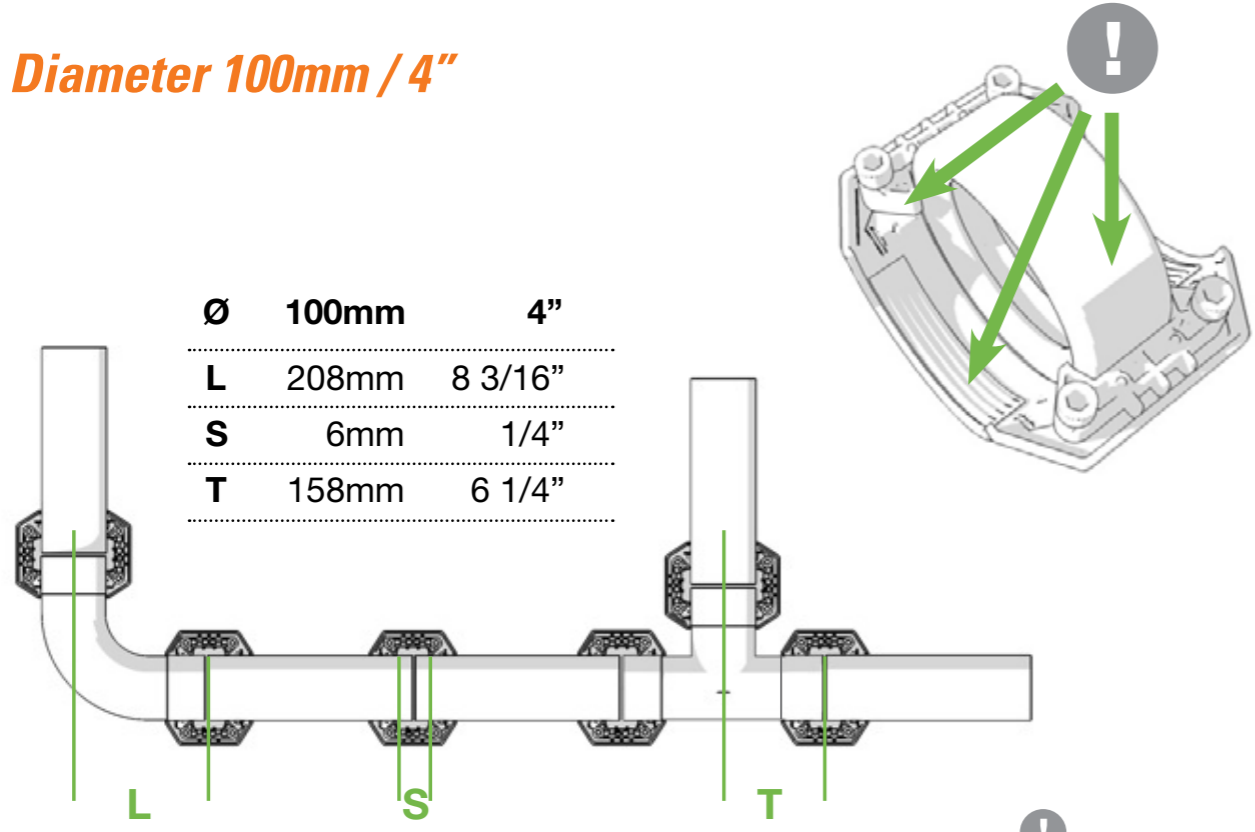

ΔT (Tmax-Tmin)	Ø100mm / 4"
5°C / 41°F	75m / 247ft
10°C / 50°F	57m / 186ft
20°C / 68°F	38m / 123ft
30°C / 86°F	29m / 94ft
40°C / 104°F	23m / 76ft

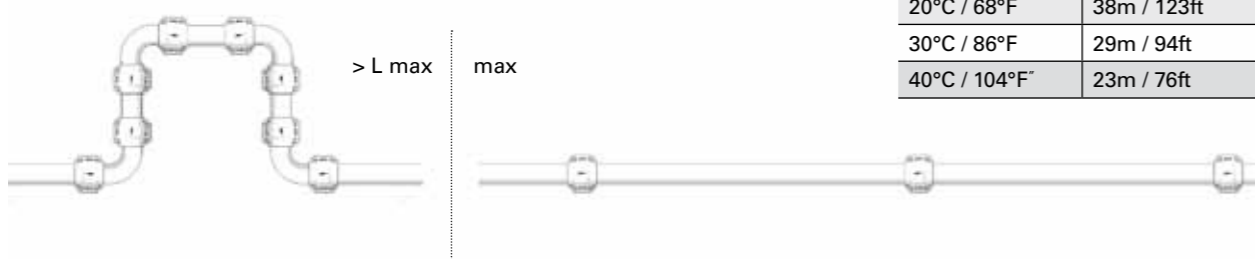

ASSEMBLY GUIDE

Diameter 100mm / 4"

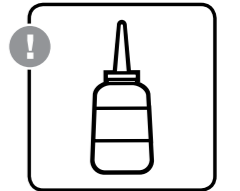
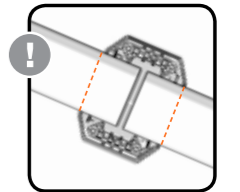
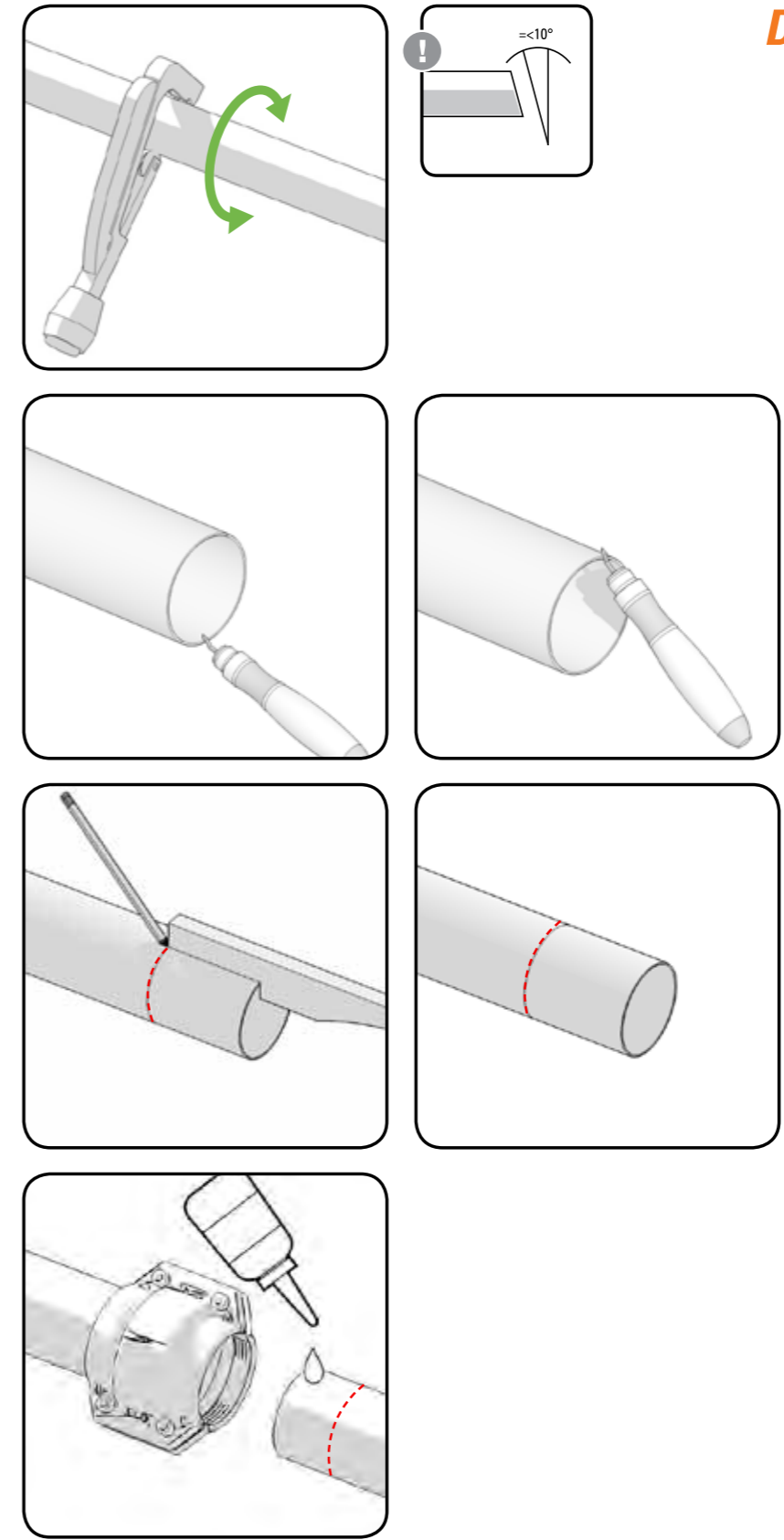

2810 0148 00

NEED TO KNOW

PRE-INSTALLATION

INSTALLATION

ASSEMBLY

SAFETY & SECURITY

NEED TO KNOW

PRE-INSTALLATION

INSTALLATION

ASSEMBLY

SAFETY & SECURITY

ASSEMBLY GUIDE

Diameter 100mm / 4"

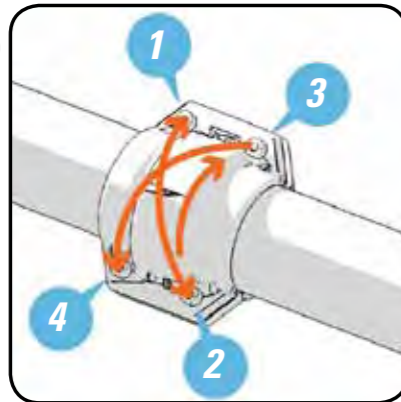
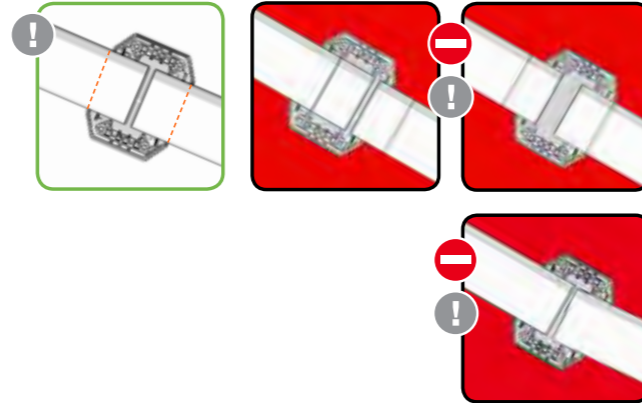
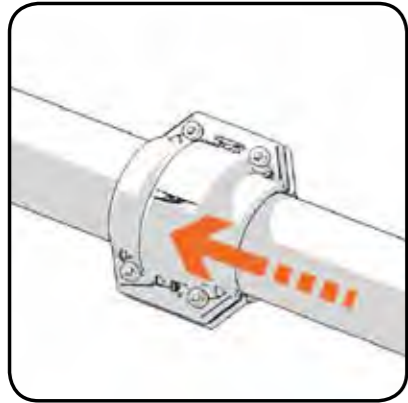

STEP 1
0-5 Nm
0-3.7 lbs/ft

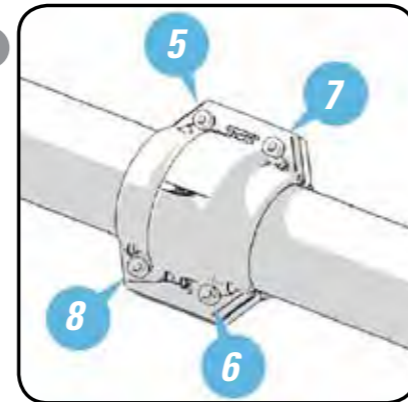

STEP 2
40Nm
29,5 lbs/ft

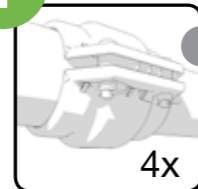
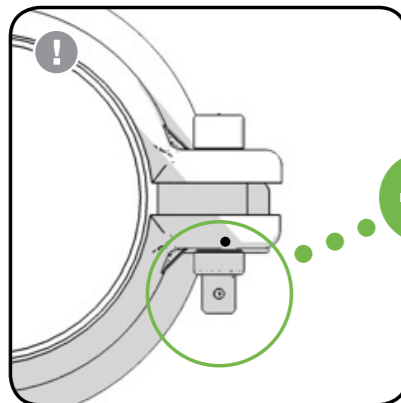
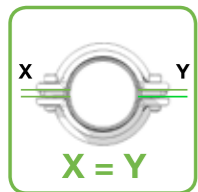

ASSEMBLY GUIDE

Quick Drop Assembly
Diameters 20 - 80mm / 3/4" - 3"

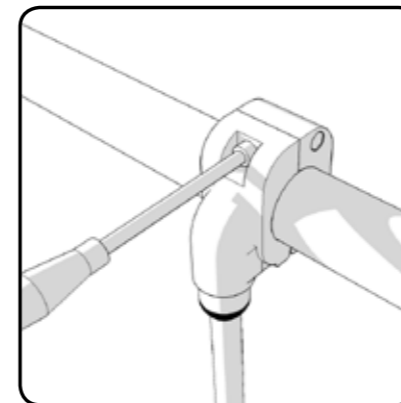
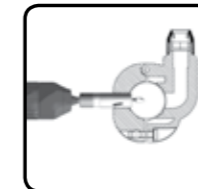
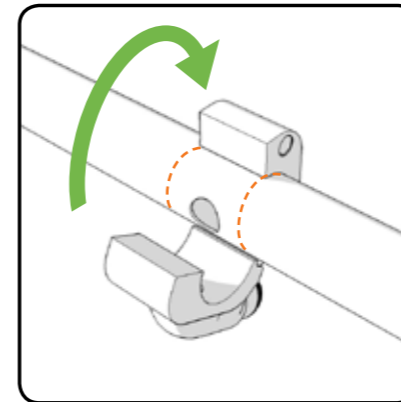
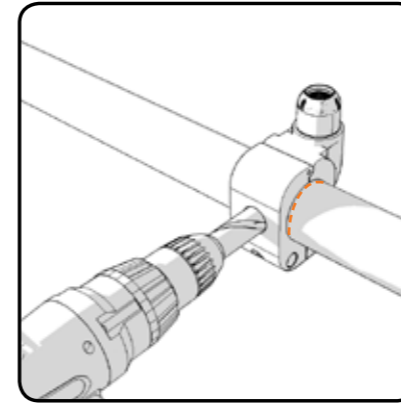
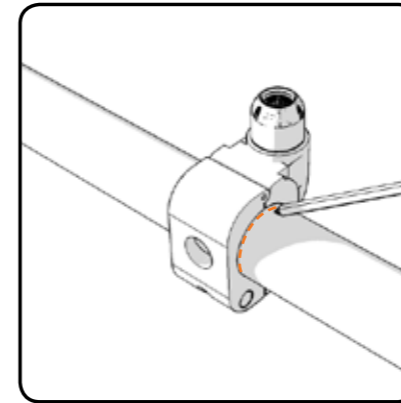

NEED TO KNOW

PRE-INSTALLATION

INSTALLATION

ASSEMBLY

SAFETY & SECURITY

NEED TO KNOW

PRE-INSTALLATION

INSTALLATION

ASSEMBLY

SAFETY & SECURITY

SAFETY & SECURITY

Operating Conditions & Safety Instructions

- AIRnet has been designed to convey compressed air.
- The installer must employ safe working practices and observe all related local work safety requirements and regulations.
- Installation, operation, maintenance and repair work must be performed by authorised, trained, specialised personnel.
- Before any installation, maintenance, repair work, adjustment or any other non-routine checks, relieve the system of pressure and effectively isolate the system from all sources of pressure.
- Never use the components below or in excess of its limit ratings.
- 13bar(e) safety valve should be present in installations for applications >13bar(e).
- AIRnet pipes and fittings are not suitable for embedded or buried installations.
- Do not use the AIRnet system as support for electrical equipment or earth conductor
- Use the correct tools
- Use only genuine parts
- The fittings are sensitive to direct UV radiation, in case of direct exposure, shield the fittings. The AIRnet pipes offer excellent resistance to UV radiation.
- Never weld or bend the pipes.
- AIRnet piping must be appropriately protected against violent impacts.
- Any plugs or caps must be removed before installing the pipes.
- Never use solvents or chemicals which can damage materials of the AIRnet.
- Check the surface of the AIRnet pipe (no relevant scratches, abrasions, dents,...) before installing
- Never connect AIRnet pipes directly to a source of vibrations, use hoses instead.
- Before using a system, an installer must ensure that all necessary test controls and applicable rules for compressed air installations are complied.
- At initial start up, apply a test pressure of 1.5 bar to the system to identify leakage or imperfect joints. After performing the inspection, increase the pressure gradually and constantly (max. 1 bar every 30 seconds).
- AIRnet is suitable for use with compressed air (lubricated, oil free, dry and wet), vacuum (20-80mm only, 0.13bar) and nitrogen gas. *

*Always consult local regulations for above use

SAFETY & SECURITY

The image displays a grid of safety and security icons for AIRnet piping. The icons are arranged in three rows and five columns. The first row shows operating conditions: temperature range (-20°C to +50°C), pressure range (4 bar to 13 bar), humidity (Rh 100%), and low temperature range (-70°C to -94°F). The second row shows prohibited actions: striking the pipe, bending the pipe, and not respecting the geometry of fittings. The third row shows material compatibility: compatible with lubricants, and reusable.

-20°C ↔ +50°C -4°F ↔ +122°F	4 bar ↔ 13 bar 60psi ↔ 188 psi	-20°C ↔ +70°C -4°F ↔ +158°F	Rh 100%	-70°C -94°F
DO NOT STRIKE	DO NOT BEND	RESPECT GEOMETRY OF FITTINGS		
COMPATIBLE WITH LUBRICANTS		REUSEABLE		

fast

Thanks to a smart design and low weight materials, AIRnet can be installed 70% faster than conventional systems.

easy

AIRnet pipes and fittings are assembled in just a few steps by a single installer, without the need for heavy machinery.

reliable

The durable, corrosion-free AIRnet pipes and fittings come with a 10-year warranty. Low friction and seamless connections minimize pressure drop.



97/23/EC
ASME B31.1
EN755
Qualicoat
Test in accordance with EN 10204
TUV Certification DR97/23/EG art. 3.3

Your Dealer